

This drawing is property of Cox Geelen and may not be copied in whole or in part without the prior written consent of the owner

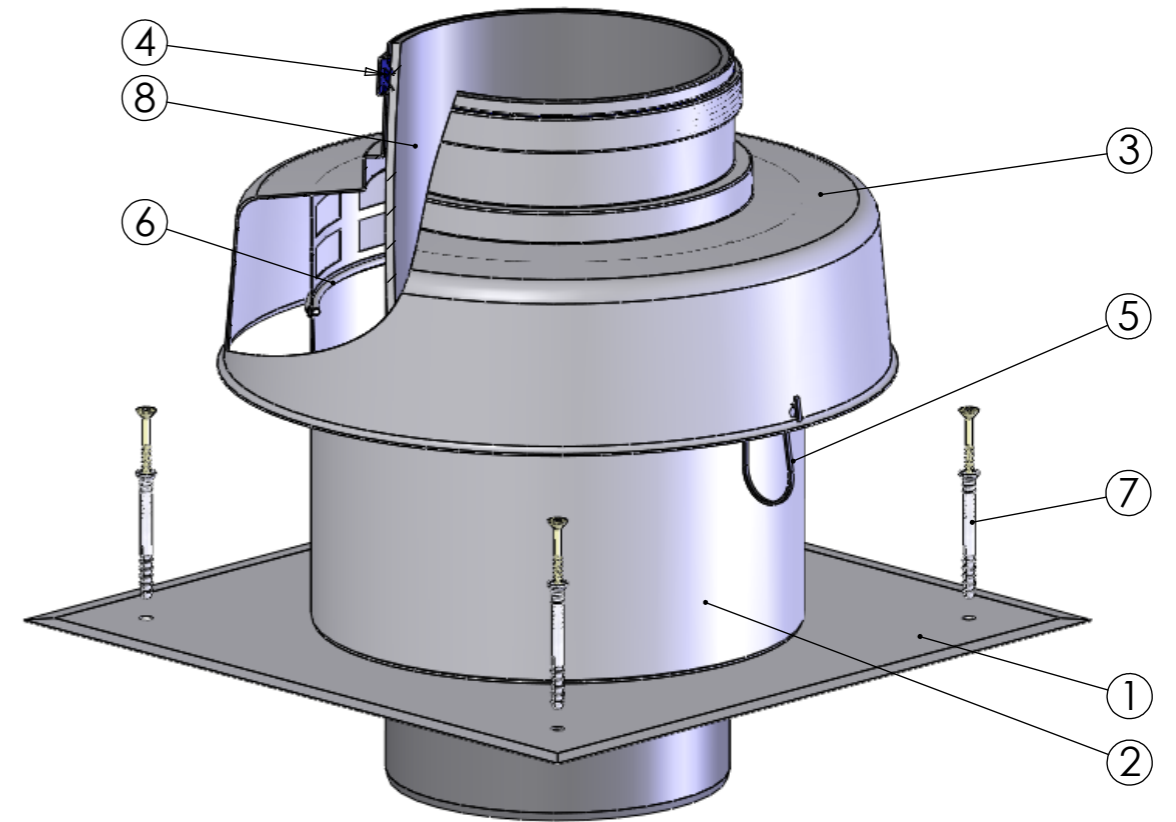
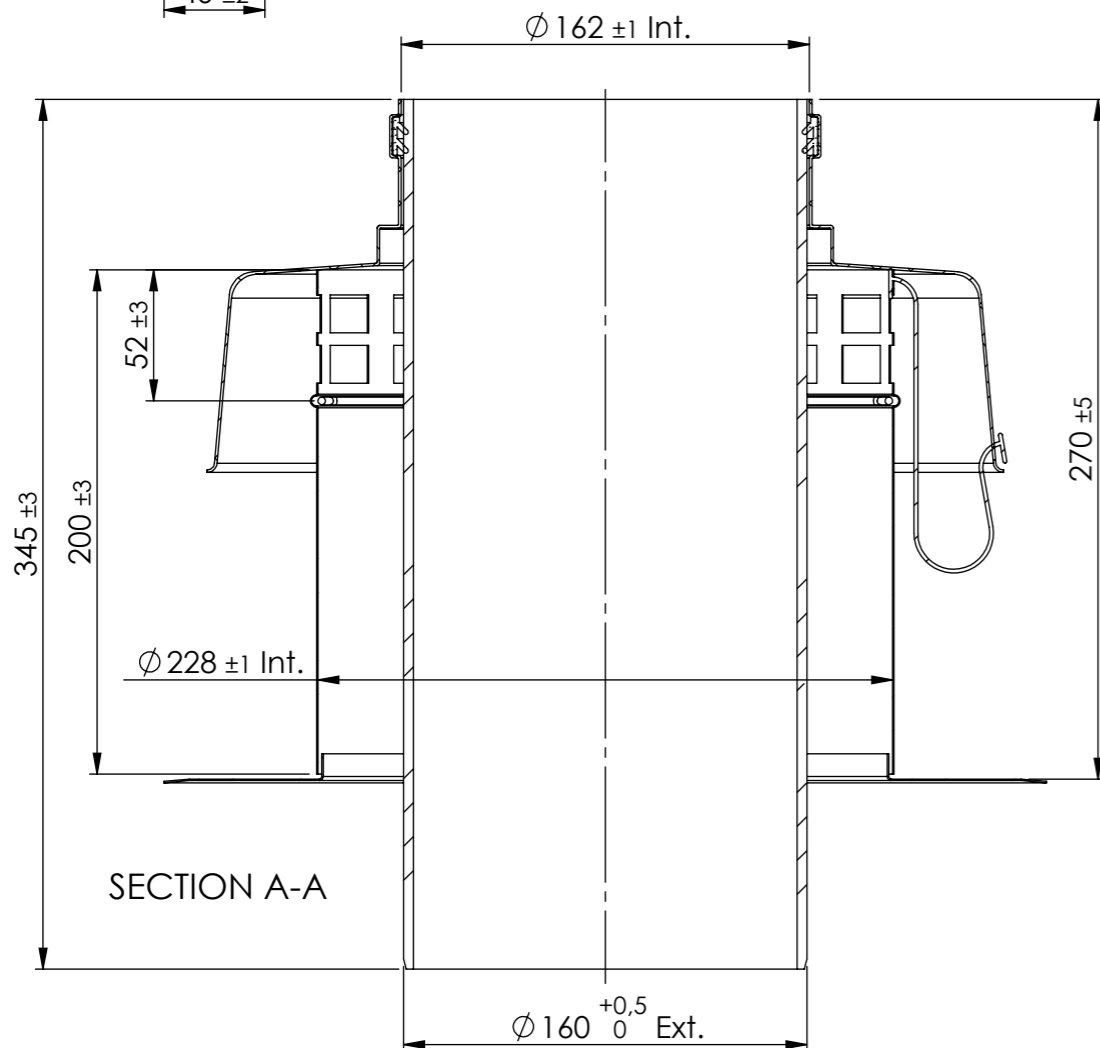
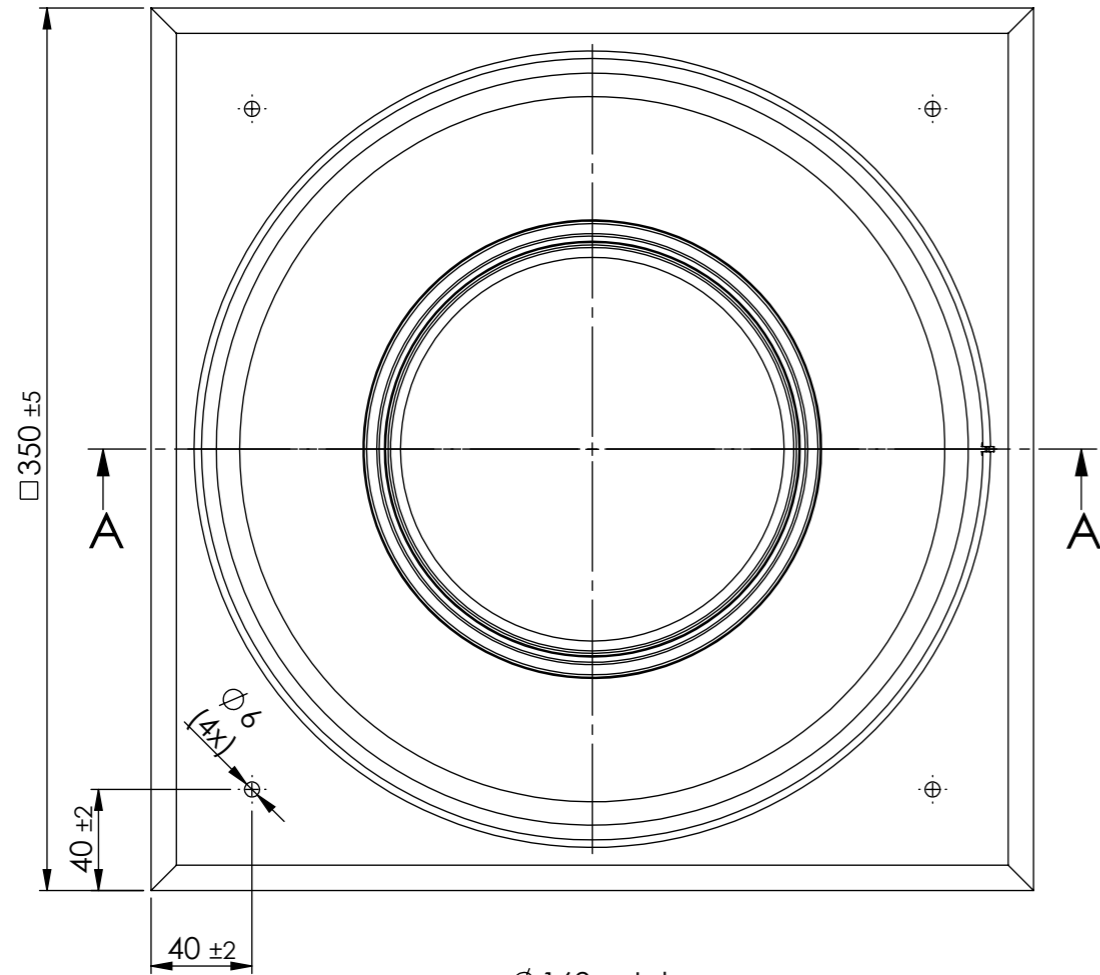

Pos.	QTY.	Description	Material	Drawing	Part nr
8	1	Flue Pipe ø160	PPs	L0291	891375
7	1	Hammerfix plug (4x)	-	-	123619
6	1	Spring	1,4310	06728	891127
5	1	Plastic cord	PA6	07160	890212
4	1	Seal ø160	Silicone	05137	700364
3	1	Shaft cover hood	EN-AW-1050A	07312	860647
2	1	Housing	DX52D+Z275-NA	-	-
1	1	Shaft cover plate	DX52D+Z275-NA	-	-

Unit of measure:	mm	Name:	M.Ubags	Date:	12-10-2011	Material:	-
Scale:	1:3	Checked:	L.Goessen	Date:	12-10-2011	Mass[g]:	2154.08

Cox Geelen
 Emmastraat 92
 6245 HZ Eijsden Nederland
 T: +31 (0) 43-4099500
 F: +31 (0) 43-4091987

Tolerances:
 $\varnothing = \pm 0.5$
 $L = \pm 3$
 $\angle = \pm 3^\circ$

Projection:

Title:
Shaft cover D160 with PPs pipe

Comments:
 Thickness of coating: >70µm

Part.no: -
 Dwg. no.: **A1765 P 00** | **A3**

00	Production drawing	11001	12-10-2011	MaUb
Revisions				